



# Catalogue ROOFTOP PACKAGE



Bryant Rooftop Package Units  
The specifications, designs, and information in this brochure are subject to change without notice

**60Hz**

# Contents

**02** Product lineups







**03** Features

**10** Specifications

**14** Dimensions

**20** Controllers

# Product lineups

Nominal ton*		7.5	10	15	20	25	30
Cooling only 220V 3N ~ 60Hz		●					
			●				
				●			
					●		
						●	●
Cooling only 460V 3N ~ 60Hz					●		
						●	●

Notes:

- \* Nominal ton only for reference.
- means cooling type product; ● means heat pump type product.
- Cooling or heating capacity as per specifications.

## Features

Wide application range

Easy installation

Easy maintenance

Outstanding reliability

Flexible choice of accessories

## Wide application range

### Wide capacity range

- ❖ Wide cooling capacity range from 5 to 30 tons.
- ❖ Heat pump and cooling only products are available.

### Wide Operation Range

Creater series rooftop package units can operate stably in a wide ambient temperature range.

Cooling only type from 10°C to 52°C in cooling mode.

Heat pump type from 10°C to 46°C in cooling mode and from -9°C to 24°C in heating mode.

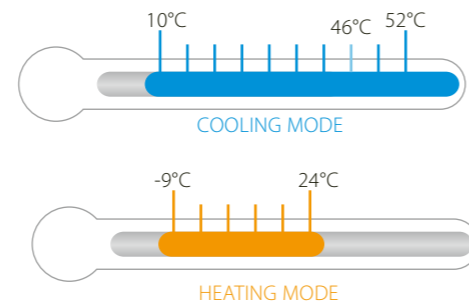

### Design flexibility

- ❖ Vertical side-discharge structure design.
- ❖ Flanges of air flow inlet and outlet as standard.
- ❖ It is suitable for installation on rooftop and ground.



## Easy installation

### Convenient for wires connection

- ❖ Removable access door on the electric box. It is easy to move the cover of the electric box.
- ❖ Only connect the wires of power supply, and no need to connect any signal wires.



### Easily connect the drainage pipe

- ❖ Reserved external drainage port, quickly and accurately connect the rubber drainage pipe.



## Easy maintenance

### External pressure gauge ports



- ❖ The unit provides external pressure gauge ports for convenient and fast checking system pressure without removing the panel. (Only for 7.5Ton-15Ton)

### Easy access doors design

- ❖ Removable the access doors on the filter, fan motor, and electric box sections.
- ❖ Provide convenient access to system components for maintenance and service.

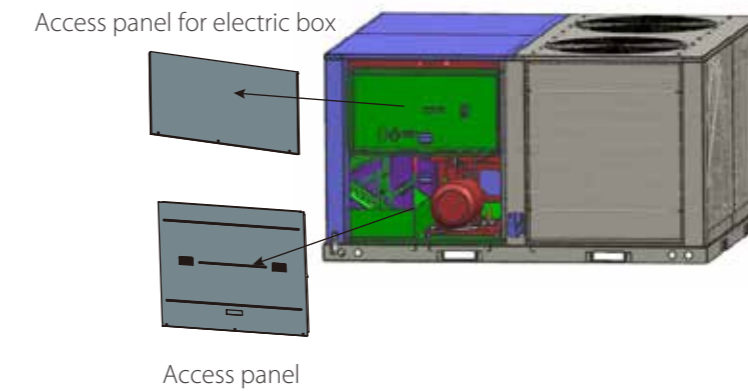

### System self-diagnostic

- ❖ Press the 'Check' button, the LED display in PCB board of the unit will display the normal checking code.
- ❖ If the unit is in running with abnormal operation, the LED display will show the error code.



### Washable filter

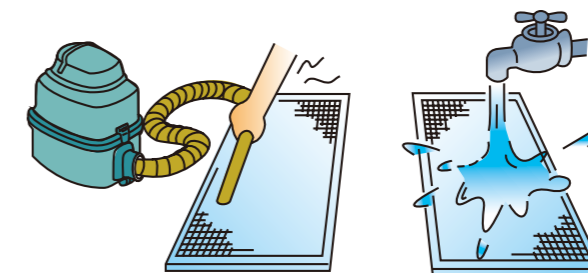

## Outstanding reliability

### Durable construction

- ❖ Pre-painted exterior cabinet panels pass 500 hours Salt Spray Test for durability.
- ❖ Weather-resistant construction with capped steams and sloped top panels.
- ❖ G90 galvanized heavy gauge plate conforming to ASTM-A-653.



### Customized anti-corrosion treatment

- ❖ The rooftop package air conditioners with special anti-corrosion treatment are suitable for seaside areas or the areas exposed to acidic substances.



- ❖ All PCB parts in the unit are coated with double-side moisture proof paint. The outer side of electric box metal cover is spray-painted.
- ❖ Special anti-corrosion treatment of heat exchanger provides 5 to 6 times greater resistance against acid rain and salt corrosion.
- ❖ All screws are anti-rust.
- ❖ Casings of the unit and motors are anti-rust.

### Reliable scroll compressor

- ❖ Famous brand compressor: Copeland, Hitachi, Danfoss, etc.. More reliable.
- ❖ No complex internal suction and discharge valves for quieter operation and higher reliability.
- ❖ Compact, light-weight, and fewer moving parts design.



### Multi-protection design

- ❖ Multiply measures to ensure units operate normally and reliably:  
System current protection, High/low pressure protection, Temperature sensor protection, etc.
- ❖ Three-phase protector can be customized.



HP/LP switch



Temperature sensor

## Flexible choice of accessories

### Controllers

- ❖ Wired controller as standard.
- ❖ Besides standard wired controller, others can be chosen too.



- ❖ Other brand thermostat can be matched as optional solution.
- ❖ Centralized control function can be achieved through the centralized controller as optional. MD-NIM01 should be connected between rooftop package units and centralized controller.



### Multi-accessories

Description	Creator series	
	Standard accessories	Optional accessories
Filter		√
Outlet drainage	√	
Snap ring	√	
Drainage pipe	√	
Anti-corrosion fin		√
EHK (Electric Heater Kits)		√
Network interface module		√
Three-phase protector		√

## Mechanical specification

### General

All units are factory assembled, internally wired, fully charged refrigerant and 100% run tested to check cooling and heating operation, fan and blower rotation, and control sequence before leaving the factory. Internal wiring is colored and numbered for simplified identification. The unit is provided with an integral weather resistant control panel.

### Casing

Unit casing is constructed of Zinc coated, heavy gauge, galvanized steel. Exterior surfaces are cleaned, G90 galvanized heavy gauge plate conforming to ASTM A653, followed by baked on electrostatic polyester dry powder coat paint on all external panels, completely weatherized for outdoor installation and properly reinforced and brazed. Salt Spray Test for steel sheet under 1000 hours, specially treated can be up to 2000 hours and even more. Cabinet construction allows for all maintenance. Service panels can be easily removed and reassembled. All panels and top covers indoor side of the unit are insulated with 16mm, foam-faced, closed-cell insulation. The unit has provisions for forklift and crane lifting, with forklift capabilities on four sides of the unit.

### Compressors

All units have direct-drive, hermetic, scroll type compressors with centrifugal type oil pump. Motor is suction gas-cooled and has a voltage utilization range of plus or minus 10 percent of unit nameplate voltage. Internal overloads are provided with the scroll compressors.

The compressors, incorporating a built-in muffler, are mounted on spring within a heavy gauge steel housing to give a low noise level.

The unit contains the best compressor technology available to achieve the highest possible performance. Dual compressors are outstanding for humidity control, light load cooling conditions and system back-up applications.

### Controls

The unit is completely factory-wired with necessary controls and terminal block for power wiring. The unit provides an external location for mounting a fused disconnect device.

Microprocessor controls provide for all 24V control functions. The precision control makes all heating, cooling, or ventilating decisions in response to electronic signals from sensors measuring indoor and outdoor temperatures.

The control maintains accurate temperature control, minimizes drift from set point, and provides better building comfort. A centralized micro-processor provides a higher level of machine protection.

### Coils

Internally finned, copper tubes mechanically bonded to a configured hydrophilic aluminum fin is standard. Coils are leak tested under 3100KPa (450 psig) at the factory to ensure the pressure integrity.

### Electronic thermostats

General information: A dedicated electronic thermostat is supplied with unit controls as standard. The thermostat normally displays room temperature and mode of operation. It also allows to select continuous fan operation, or has the fan on intermittent operation with the equipment. Finally, it displays the status of unit, thus providing maximum information for the user.

# Specifications



# Specifications

Cooling only, 220V 3N~ 60Hz

7.5RT



10RT



15RT



Nominal ton*			7.5	10	15
Model			BRTPO8M-5A-1	BRTP12M-5A-1	BRTP16M-5A-1
Cooling	Capacity (1)	Btu/h	89,000	120,000	180,000
		W	26,100	35,200	52,800
	Input (1)	W	7,800	10,700	16,200
	EER (1)	Btu/h.W	11.4	11.2	11.1
Air flow	Indoor side	CFM	2,700	4,120	6,450
External static pressure		Pa	Default: 80; 0 - 250	Default: 90; 0 - 250	Default: 110; 0 - 300
Max. power input		W	11,300	17,500	25,000
Max. current		A	42.4	57.4	88.3
Compressor	Type / Quantity		Scroll / 1	Scroll / 1	Scroll / 2
	Brand		Copeland	Copeland	Copeland
Indoor fan	Type / Drive type		Centrifugal / Direct	Centrifugal / Belt	Centrifugal / Belt
Outdoor fan	Type / Drive type		Axial / Direct	Axial / Direct	Axial / Direct
Wired controller			KJR-25B	KJR-12B/dP(T)-E	KJR-12B/dP(T)-E
Centralized controller (Optional)			Yes	Yes	Yes
Refrigerant	Type	/	R410A	R410A	R410A
	Control	/	Throttle valve	Throttle valve	Throttle valve
	Charged	kg		3.8	4.1
lbs			8.36	9.02	10.12+4.84
Sound pressure level		dB(A)	75.6	75.7	76.8
Ambient temperature			10°C - 52°C	10°C - 52°C	10°C - 52°C
Dimension	Net (WxHxD)	mm	1,475x840x1,130	1,483x1,231x1,138	1,965x1,230x1,130
	Packing (WxHxD)	mm	1,495x870x1,150	1,500x1,255x1,155	1,995x1,255x1,160
Weight	Net / Gross	kg	235/240	325/335	470/485

Notes:

1. Cooling capacity test condition (1): Outdoor ambient temperature: 35°C, indoor temperature 26.7°C DB / 19.4°C WB;
2. Units are suitable for operation to ±20% of nominal CFM;
3. Sound values are measured in a semi-anechoic room, at a position 1m in front of the unit and (1 meter + height of unit)/2 above the floor.
4. Specifications are subject to change without prior notice for product improvement.
5. \* Nominal ton only for reference.
6. Cooling capacity as per specifications.

# Specifications

Cooling only 220V 3N~ 60Hz

20RT



25&30RT



Nominal ton*			20	25	30
Model			BRTP24M-5A-1	BRTP28M-5A-1	BRTP30M-5A-1
Cooling	Capacity (1)	Btu/h	240,000	300,000	360,000
		W	70,300	87,900	105,500
	Input (1)	W	21,900	27,800	37,000
	EER (1)	Btu/h.W	11.0	10.8	9.7
Air flow	Indoor side	CFM	8,580	11,138	11,000
External static pressure		Pa	Default: 120; 0 - 375	Default: 250; 125 - 450	Default: 270; 0 - 400
Max. power input		W	36,000	45,000	45,800
Max. current		A	124.6	150.0	148.0
Compressor	Type / Quantity		Scroll / 2	Scroll / 2	Scroll / 2
	Brand		Copeland	Copeland	Copeland
Indoor fan	Type / Drive type		Centrifugal / Belt	Centrifugal / Belt	Centrifugal / Belt
Outdoor fan	Type / Drive type		Axial / Direct	Axial / Direct	Axial / Direct
Wired controller			KJR-12B/dP(T)-E	KJR-12B/dP(T)-E	KJR-12B/dP(T)-E
Centralized controller (Optional)			Yes	Yes	Yes
Refrigerant	Type	/	R410A	R410A	R410A
	Control	/	Throttle valve	Capillary	Capillary
	Charged	kg		5.4+5.4	6.7+6.7
lbs			11.88+11.88	14.74+14.74	15.62+15.62
Sound pressure level		dB(A)	78.3	79.2	77.9
Ambient temperature			10°C - 52°C	10°C - 52°C	10°C - 52°C
Dimension	Net (WxHxD)	mm	1,670x1,247x2,192	2,320x1,245x2,220	2,220x1,245x2,320
	Packing (WxHxD)	mm	1,695x1,284x2,212	2,330x1,275x2,230	2,230x1,275x2,330
Weight	Net / Gross	kg	670/700	895/925	940/970

Notes:

1. Cooling capacity test condition (1): Outdoor ambient temperature: 35°C, indoor temperature 26.7°C DB / 19.4°C WB;
2. Units are suitable for operation to ±20% of nominal CFM;
3. Sound values are measured in a semi-anechoic room, at a position 1m in front of the unit and (1 meter + height of unit)/2 above the floor.
4. Specifications are subject to change without prior notice for product improvement.
5. \* Nominal ton only for reference.
6. Cooling capacity as per specifications.

# Specifications

Cooling only 460V 3N~60Hz

20RT



25&30RT



Nominal ton			20	25	30
Model			B RTP24M-6A	B RTP28M-6A	B RTP30M-6A
Power supply			460V 3N~60Hz	460V 3N~60Hz	460V 3N~60Hz
Cooling	Capacity(1)	Btu/h	240,000	300,000	360,000
		kW	70.3	87.9	105.5
	Input(1)	kW	23.6	33.0	37.9
	EER(1)	Btu/h.W	10.2	9.1	9.5
Air flow	Indoor side	CFM	8,300@120Pa	11,500@130Pa	11,000@270pa
External static pressure		Pa	Default: 120; 0 - 400	Default: 250; 125 - 450	Default: 270; 0 - 400
Max. input consumption		kW	36.0	45.0	46.8
Max. current		A	60.8	66.2	<b>74.5</b>
Compressor	Type		Scroll	Scroll	Scroll
	Quantity		2	2	2
Indoor fan	Type / Drive type		Centrifugal / Belt	Centrifugal / Belt	Centrifugal / Belt
	Quantity		1	1	1
Outdoor fan	Type / Drive type		Axial / Direct	Axial / Direct	Axial / Direct
	Quantity		2	2	2
Wired controller			KJR-12B/dP(T)-E	KJR-12B/dP(T)-E	KJR-12B/dP(T)-E
Centralized controller (Optional)			Yes	Yes	Yes
Refrigerant	Type	/	R410A	R410A	R410A
	Control	/	Throttle valve	Capillary	Capillary
	Charged	kg	5.4+5.4	6.1+6.1	7.6+7.6
		lbs	11.88+11.88	13.42+13.42	16.72+16.72
Sound pressure level		dB(A)	78.3	79.2	77.9
Ambient temperature			10°C - 52°C	10°C - 52°C	10°C - 52°C
Dimension	Net (WxHxD)	mm	2,192x1,247x1,670	2,220x1,245x2,320	2,220x1,245x2,320
	Packing (WxHxD)	mm	2,212x1,284x1,695	2,230x1,275x2,330	2,230x1,275x2,330
Weight	Net / Gross	kg	670/700	895/925	940/970

Notes:

- Cooling capacity test condition (1): Outdoor ambient temperature: 35°C, indoor temperature 26.7°C DB / 19.4°C WB;
- Units are suitable for operation to ±20% of nominal CFM;
- Sound values are measured in a semi-anechoic room, at a position 1m in front of the unit and (1 meter + height of unit)/2 above the floor.
- Specifications are subject to change without prior notice for product improvement.
- \* Nominal ton only for reference.
- Cooling capacity as per specifications.

# Dimensions





6.2RT & 7.5RT  
(Units: mm)

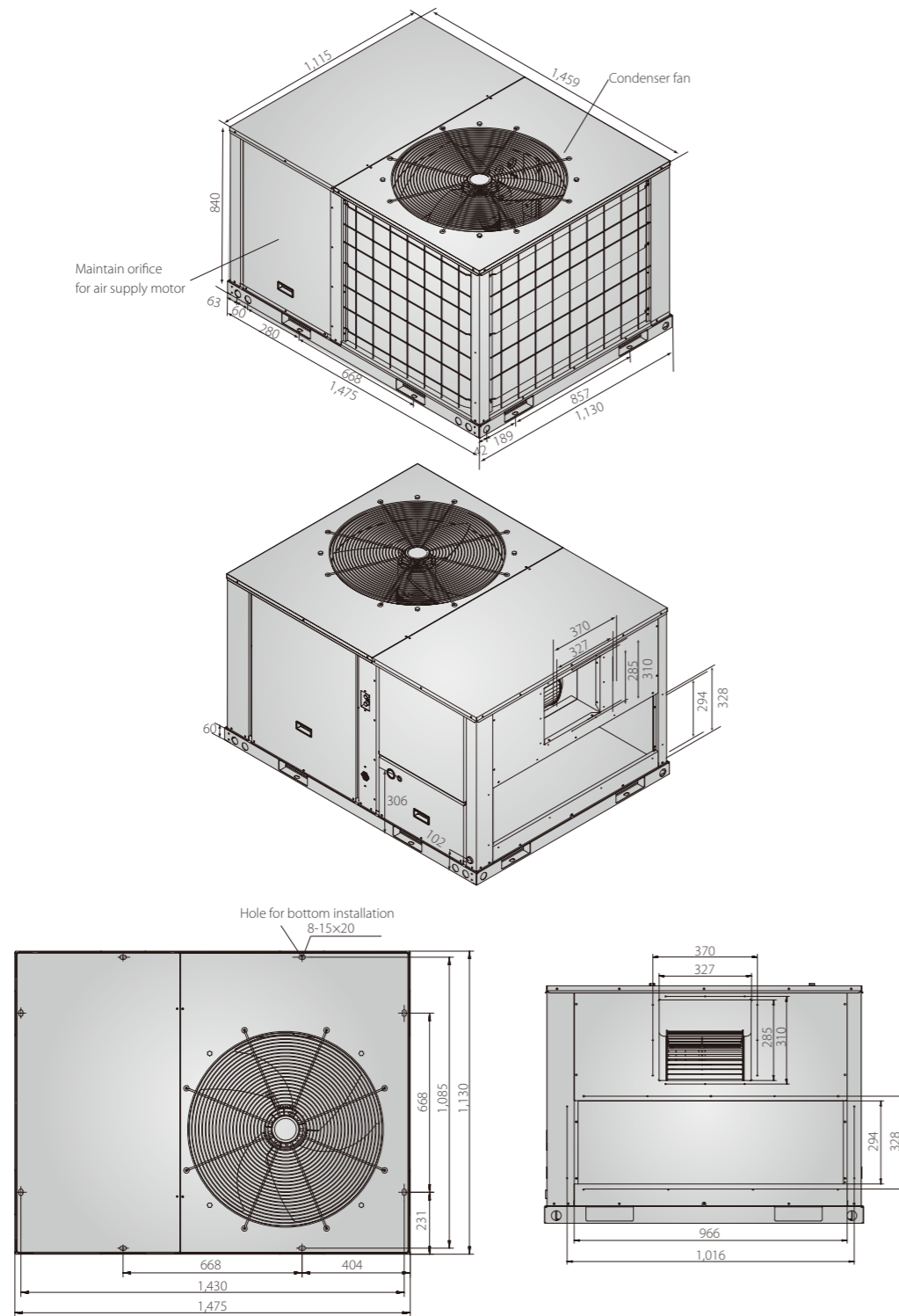

8.5RT & 10RT  
(Units: mm)

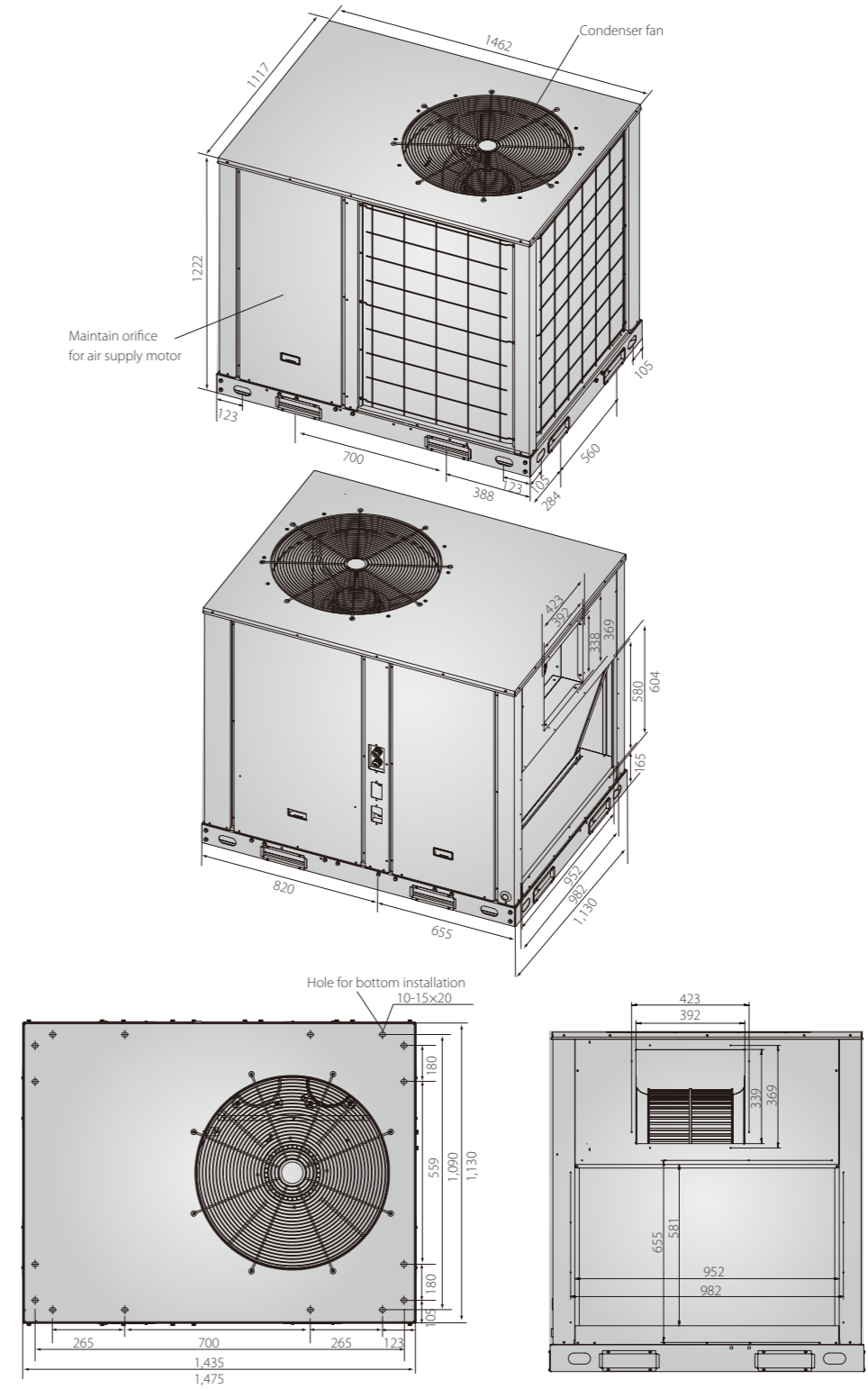

12.5RT & 15RT  
(Units: mm)

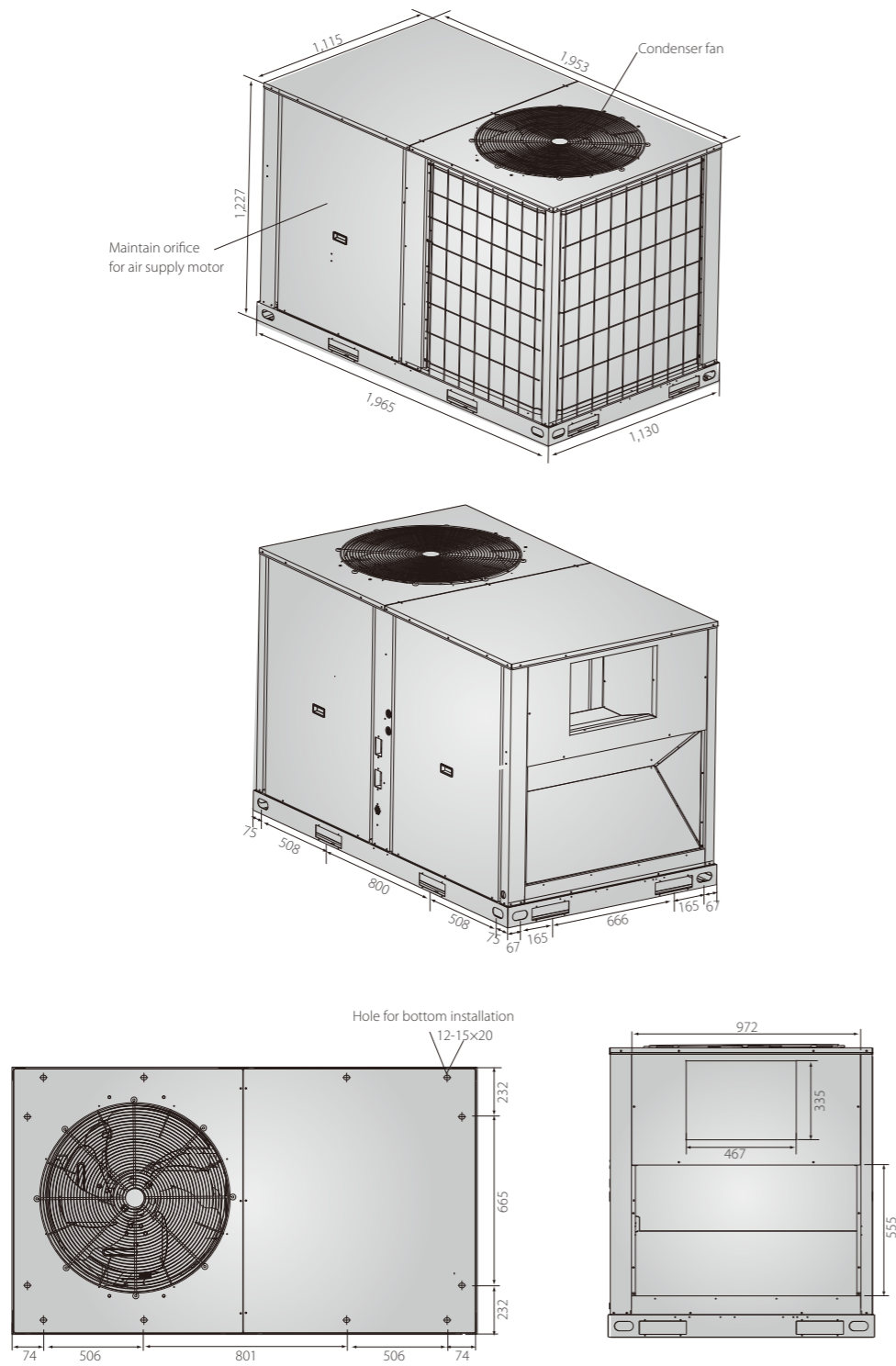

17.5RT & 20RT  
(Units: mm)

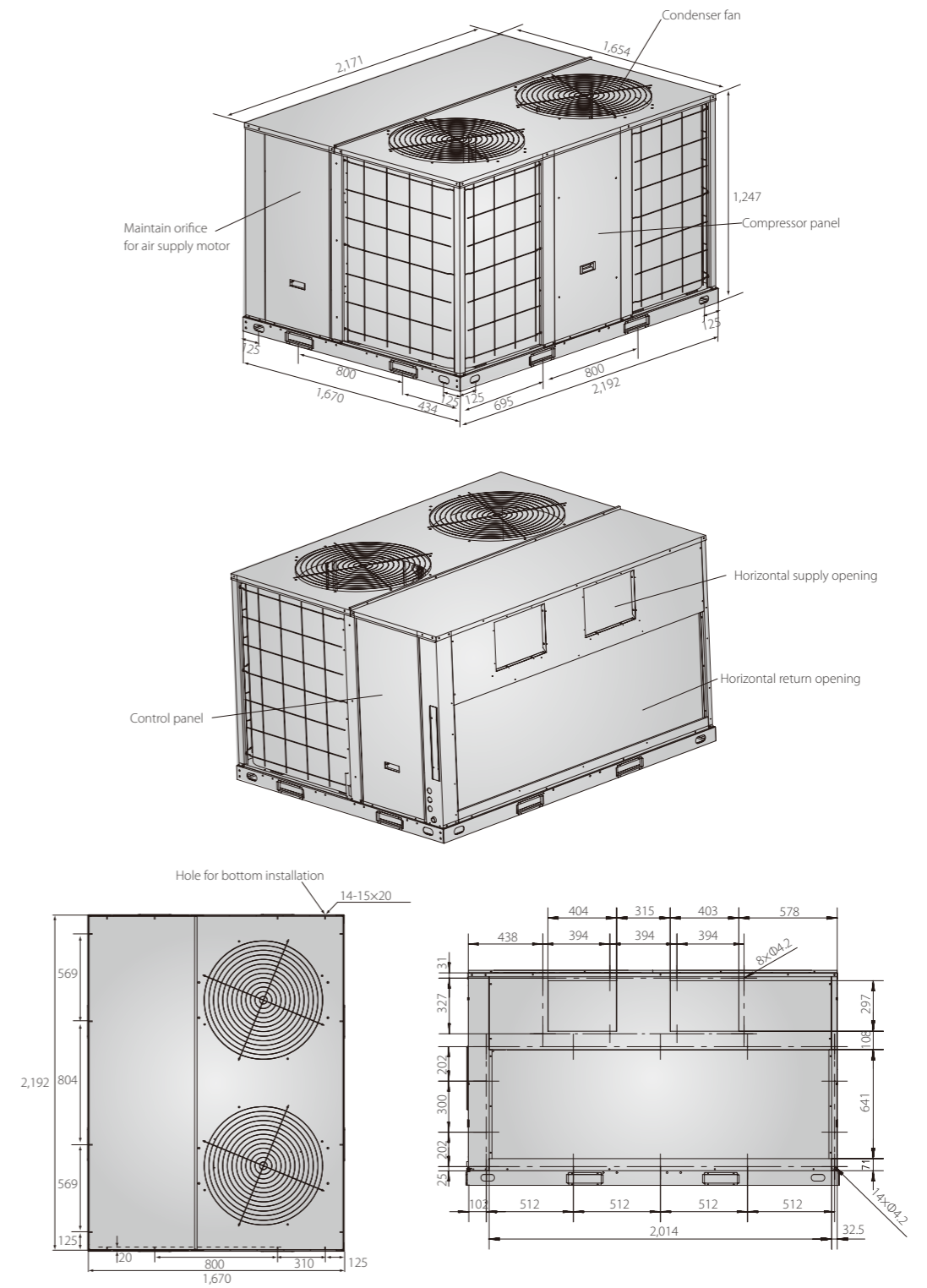

25RT & 30RT  
(Units: mm)

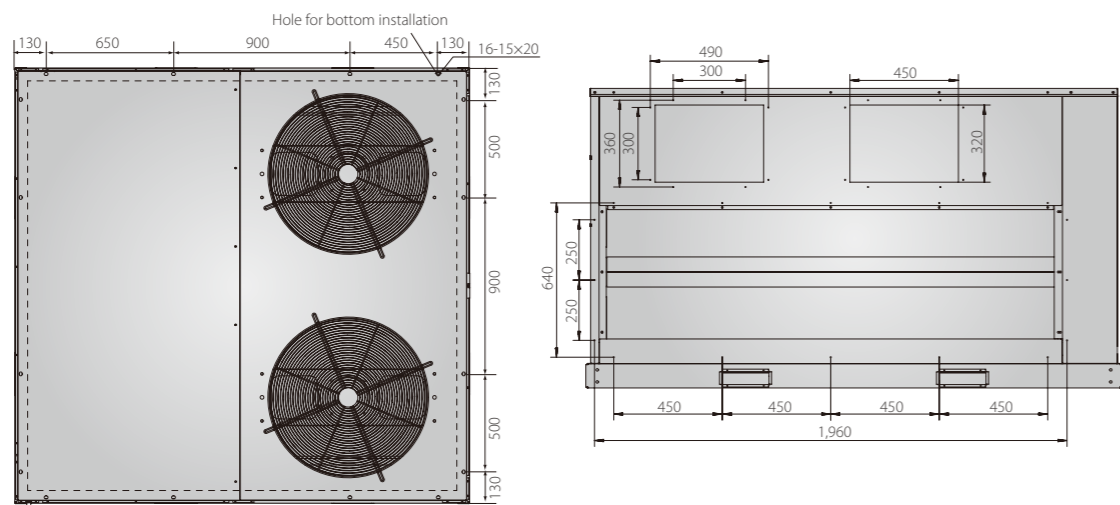
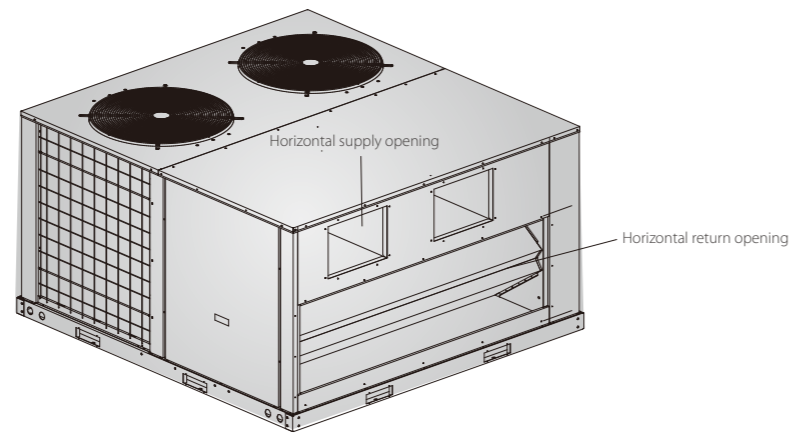
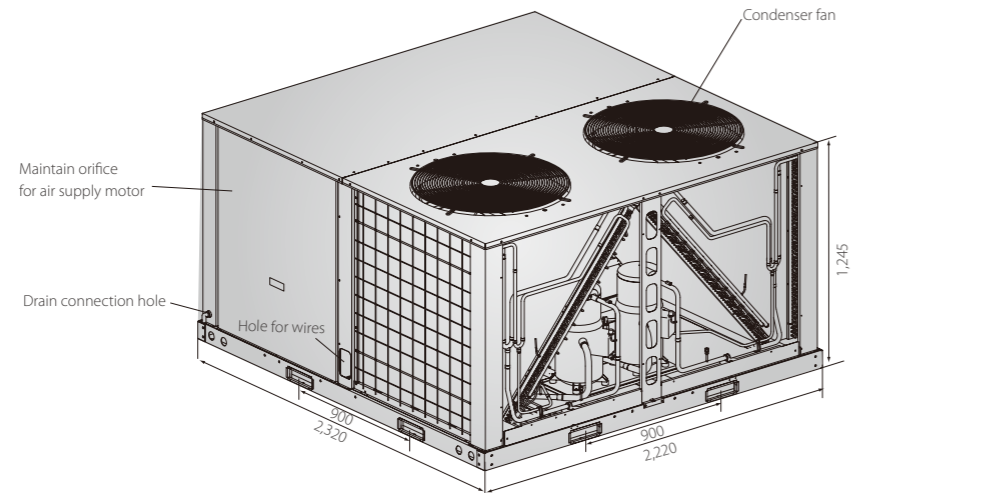

# Controllers



## Wired controllers

Model				
Model	WR-90K-CM	WR-12B-CM	WR-25B-CM	WR-29B-CM
Key type	Touch key	Button key	Button key	Touch key
On / Off	●	●	●	●
Mode selection	●	●	●	●
Temperature setting	1°C steps	1°C steps	1°C steps	1°C steps
Fan mode selection	●	●	●	●
Follow me	●	●	×	●
Eco mode	●	●	×	×
Room temperature display	●	●	●	●
°F/°C display	●	●	●	●
Daily timer	●	●	●	●
Keyboard lock	●	●	×	●
Background light	●	●	●	●
Bi-directional communication	●	×	×	×
Clean filter reminder	●	×	●	●
Language	English	English	English	English
Error check function	●	●	×	×
System parameter querying	●	×	×	×
Dimensions (WxHxD) (mm)	86x86x18	120x120x20	140x95x30	120x120x20
Power supply	18V DC	5V DC	AC24V	5V DC

Note:  
 ●: equipped as standard; ×: without this function  
 The optional wired controllers to each unit referring to electrical wiring diagram.

## Central controller



CRF-40-CM



MD-NIM01

- ❖ Central control function. It is a multifunctional device which is able to control up to 64 units.
- ❖ The control object can be either single or all, making the controlling operation convenient. It also easy to check all units status.



- ❖ Two structures of centralized central design, easy installation.



Structure A



Structure B

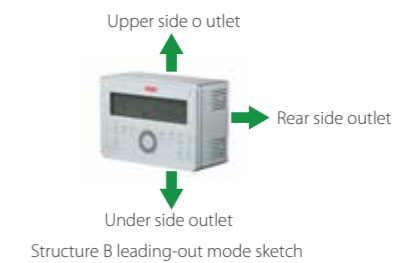

Structure B leading-out mode sketch